

Plan View
Evaporator Mezzanine

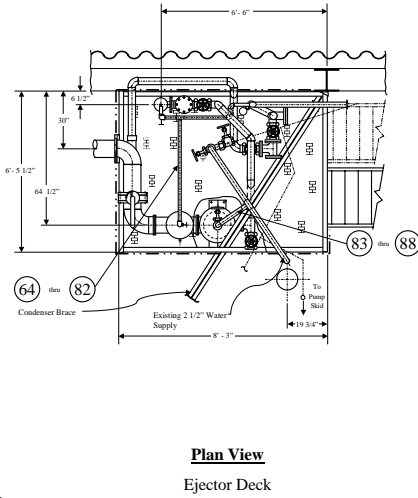

Plan View
Ejector Deck

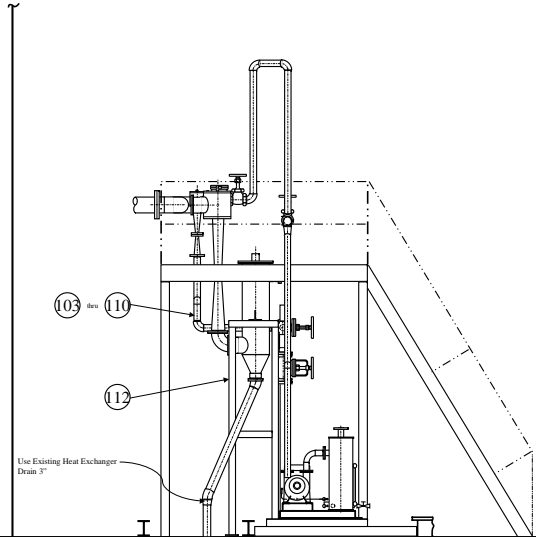

Elevation View A-A
Evaporator Mezzanine
(Looking East)

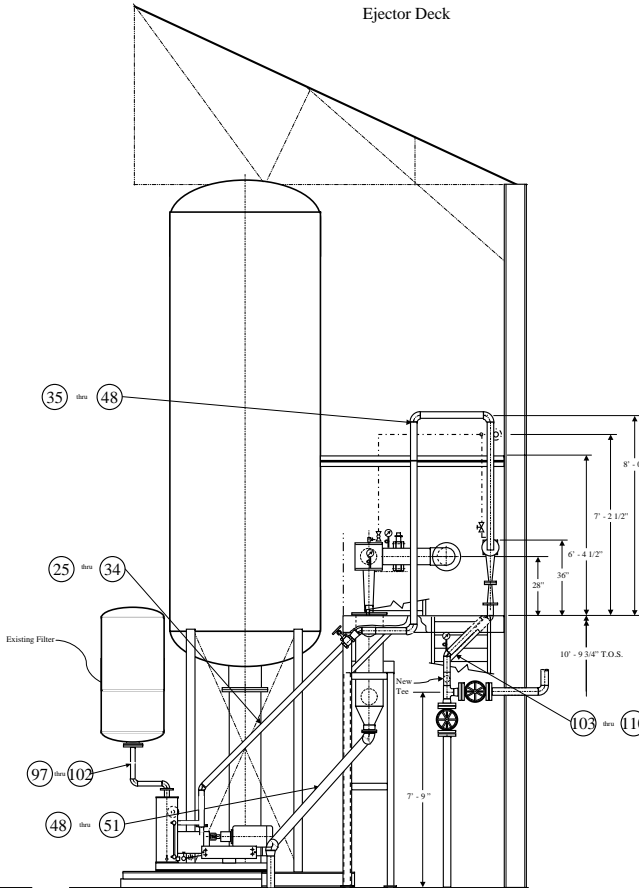

Elevation View B-B
Evaporator Mezzanine
(Looking North)

Bill of Materials									
Item No.	Description	Joint	Size	Material	Qty	Description	Joint	Size	Material
1	Main Components								
11	Flange 8\"/>								

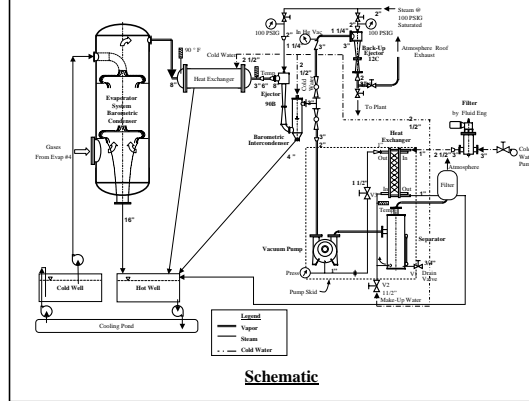

Schematic

Industrial Architectural Plan
Newark, CA

PROCESS PIPING
SAMPLE

Scale: NOTES by: M McCarron
REV: A Date: 01/09/99 E - PIPING2