

PLAN VIEW

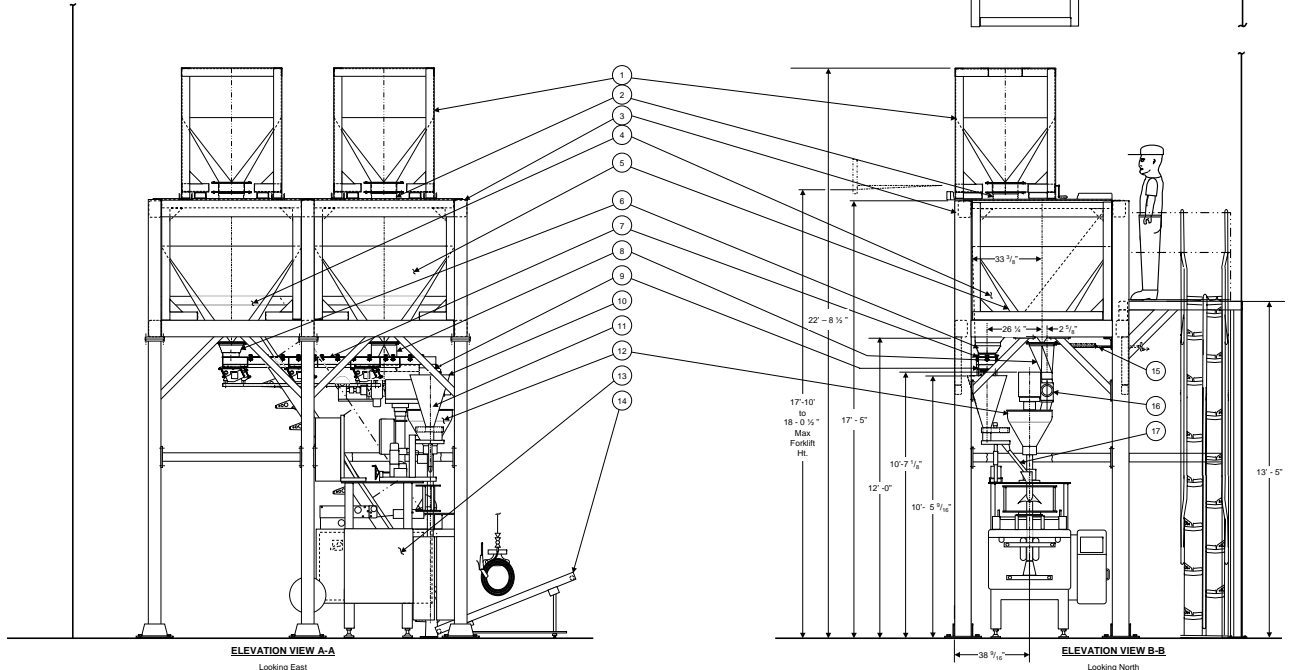

ELEVATION VIEW A-A
Looking East

ELEVATION VIEW B-B
Looking North

EQUIPMENT LIST

1	Portable Hopper	D 1199
2	Fabric Sock, Portable Bin Qty=2. See Detail 9	E 1203
3	Deck Assembly	E 1168
4	Surge Bin, Cup Filler	D 1200
5	Surge Bin, Main Auger	D 1198
6	Fabric Sock, Cup Filler Surge Bin. See Detail 10	D 1203
7	Vibratory Conveyor Cup Filler, Erect	D 1201
8	Discharge Chain Main Auger Surge Bin. See Detail 2	D 1203
9	Fabric Sock, Vibratory Conveyor Disch. See Detail 11	D 1203
10	Cup Filler Lid. See Detail 5	D 1203
11	Cup Filler Assembly, Speedee	D 1197
12	Main Auger Filler, Speedee	D 1197
13	Bagger, Doboy	D 1197
14	Bag Conveyor, Doboy	D 1197
15	Slide Gate Handwheel Assy Qty=2	D 1198
16	Screw Conveyor, Main Auger, Speedee	D 1197
17	Discharge Chain, Cup Filler	D 1197
18	Bin Vibrator, Air Powered, Vibco VS - 250	D 1198
19	Shaker Isolation Pad. See Detail 8	D 1203

NOTES:
 1. THIS IS A DESIGN BUILD PROJECT. The equipment and details as shown on the drawings are intended to describe the general scope of work required and are not intended to be exact. Deviations may occur during field installation. Installer is contracted to perform design services, and field verify dimensions as required to complete the scope. Any major discrepancies to the drawings are to be reported to the owner and/or engineer prior to commencement of work affecting the contracted scope.
 2. Not Shown.
 3. Make as close to wall as possible, depending on concrete saw distance from blade.
 4. All gasketing to be FDA approved white neoprene.
 5. To Be Provide By Client.

DRAWING LIST

D 1197	Doboy/Speedee Packing Machine Assy
D 1198	Main Auger Surge Bin
D 1199	Portable Hopper
D 1200	Cup Filler Surge Bin
D 1201	Erect Shaker Conveyor
D 1203	Miscellaneous Details
D 1204	Compressed Air Piping
E 1167	General Arrangement
E 1168	Deck Structural Steel & Foundation Details

Vertical Form, Fill, & Seal Packing Line

SAMPLE
 Mechanical Plan
 Hayward, CA



Scale: 1/2"=1' by: M McCarron
 REV: A Date: 4/14/03 E - MECH